

SHENZHEN GROWATT NEW ENERGY TECHNOLOGY CO.,LTD

No.28 Guangming Road, Shiyao Street, Bao'an District,
Shenzhen, P.R.China

T + 86 755 2747 1942

F + 86 755 2747 2131

E service@ginverter.com

W www.ginverter.com

ShineMaster User Manual

CONTENT

1 About the user manual

- 1.1 Manual description
- 1.2 Copyright statement
- 1.3 Applicable personnel
- 1.4 Manual use

2 Product description

- 2.1 Device Overview
- 2.2 Unpacking
- 2.3 ShineMaster Network Introduction

3 Installation and Connection

- 3.1 ShineMaster installation environment
- 3.2 ShineMaster installation method
- 3.3 Connect to the photovoltaic device

4 ShineMaster built-in page parameter setting

- 4.1 ShineMaster IP address query
- 4.2 ShineMaster built-in page access
- 4.3 ShineMaster Status View
- 4.4 ShineMaster Datalogger managing
- 4.5 Baud Rate Setting
- 4.6 Server Address and Shine Master IP setting

5 Server: Shineserver's operation

- 5.1 Registration and login
- 5.2 View monitoring data
- 5.3 Add or Delete Monitoring devices, change the ShineMaster Baud rate

6 Device Maintenance

- 6.1 Common faults and troubleshooting
- 6.2 Maintenance

7 Technical specifications

- 7.1 ShineMaster specification

8 Contact us

1 About the user manual

1.1 Manual description

Dear users, thank you very much for using the ShineMaster data logger (hereinafter referred to as ShineMaster) developed and produced by Shenzhen Growatt New Energy Co., Ltd. (hereinafter referred to as Growatt). We sincerely hope that this product will meet your needs and expect you give more opinions on the performance and function of the product. The purpose of this manual is to provide users with detailed product information and instructions for installation, operation, and maintenance.

1.2 Copyright statement

This user manual is copyrighted by Growatt. Any unit or individual may not excerpt or copy part or all of this user's manual without the written permission of the company. It may not be transmitted in any form, including materials and publications. Infringement must be investigated.

The version of this manual is V1.1. Growatt owns the final interpretation right of this user manual. If there is any change in product parameters, appearance, packaging, etc., the latest information of the company shall prevail without notice.

1.3 Applicable personnel

This manual is for professional technicians who install, commission, and maintain the ShineMaster and for users who perform daily operations. This manual does not include electrical connections for inverters, combiner boxes, weather stations, smart meters, and anti-reflux devices, as well as related precautions. If necessary, refer to Growatt's corresponding user manual or instruction.

1.4 Manual usage

Please read this manual carefully before using ShineMaster. At the same time, please keep this manual in a safe place so that operators and maintenance personnel can find out. The contents of the manual will be continuously updated and corrected. It is inevitable that there will be slight inaccuracies or errors in the actual contents. Users should refer to the actual product purchased. The latest user manuals can be downloaded from www.ginverter.com, and can also be obtained through Growatt's sales or service channels.

2 Product description

2.1 Device Overview

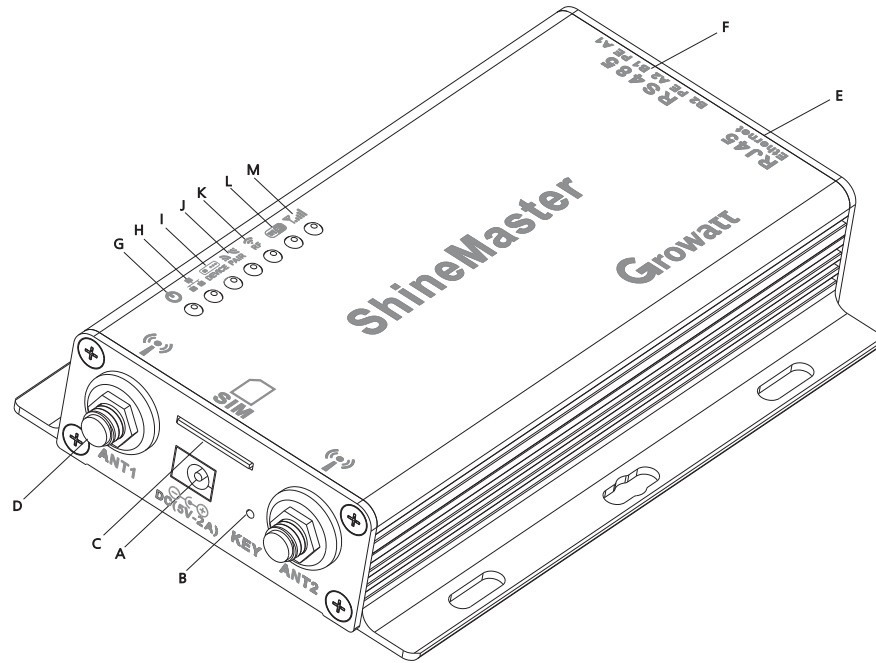

Fig.2-1

2.1.1 Interface

The interface of ShineMaster, as shown in figure 2-1 above.

The functional description of each interface is shown in table 2-1.

Item	Name	Function
A	POWER	Power supply port
B	KEY	Reset button (temporarily unavailable)
C	SIM	SIM card slot
D	ANTENNA	Antenna, used to receive wireless signals (Temporarily not supported)
E	LAN	RJ45 port: Connect Shine ShineMaster to the local network area of Shine Server through RJ45 cable
F	RS-485	Two-way RS485 interface

Table 2-1

2.1.2 Indicator Led

ShineMaster is equipped with seven LED indicators. The status of the ShineMaster can be displayed by the LED indicator. As shown in figure 2-1 and table 2-2 above.

Item	Name	Function
G	Power LED	Power indicator light, constant on means power supply is normal
H	Network LED	Network light: 1: off means fail to obtain IP address; 2: flashing means connecting to the server; 3: on means connection to the server successfully
I	Device LED	The number of the LED continuously flashing means the device number connected to the ShineMaster
J	Configuration LED	Flashing when configuration , if successful , the LED will be off (temporarily unavailable)
K	RF	RF signal indicator (temporarily unavailable)
L	WiFi	WiFi signal indicator (temporarily unavailable)
M	2G/4G	2G/4G signal indicator (temporarily unavailable)

table 2-2

2.2 Unpacking

2.2.1 Packing List

ShineMaster and accessories can be found as below figure 2-2:

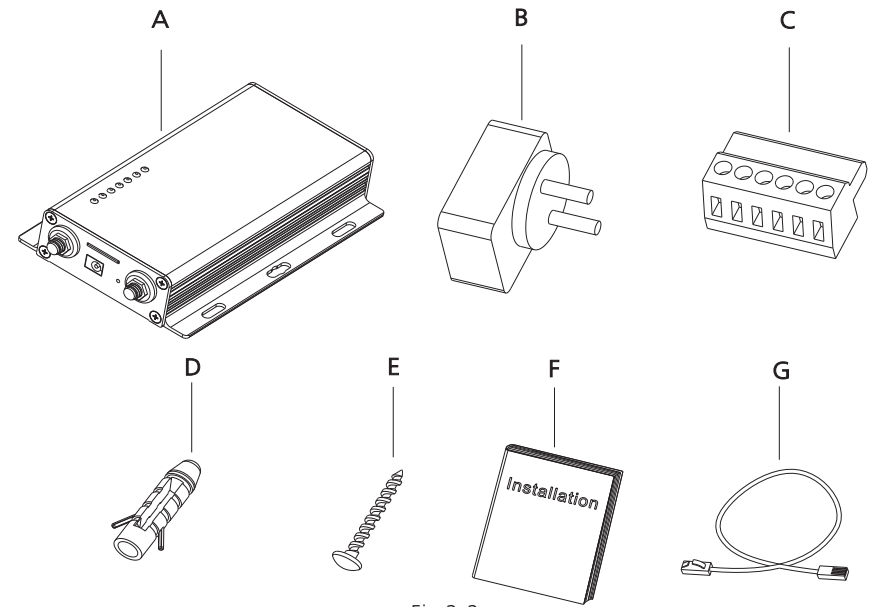

Fig 2-2

Item	Name	Amount
A	ShineMaster	1 pcs
B	5V power adapter	1 pcs
C	Terminal RS485	1 pcs
D	Wall plastic column	4 pcs
E	M3.5*20 screw	4 pcs
F	ShineMaster user manual	1 pcs
G	Ethernet cable	1 pcs

Table 2-4

2.2.2 Serial No. and Check Code

The ShineMaster serial No. (S/N) and check code (C/C) is ticked on the ShineMaster's package box, which have 10 digits mixed up with letters and numbers. the serial No. and check code for each device are unique, to identify each ShineMaster. When you want to upload the data of ShineMaster to the server, you need the serial No. and 'check code' corresponding to register on the server

2.3 ShineMaster Network Introduction

ShineMaster supports network communication, which can be communicated via wired WLAN, wireless WiFi, 2G/4G, GPRS and cloud server. Upload the monitored data to the server of Growatt, and then access the server's domain name. Realize industrial common communication mode RS485 and wireless RF communication, also supports wired and wireless communication ways to monitor and set slave devices and perform online upgrades on devices. By accessing ShineMaster's internal IP address, you can enter the built-in page for parameter setting and device addition viewing (please refer to section 4.4 below).

ShineMaster monitors the photovoltaic devices through RS485 and RF(temporarily not supported). The diagram below shows the schematic diagram of network monitoring through wired RS485.

Note: The precondition of local access is that the address of PC and ShineMaster must be in the same domain, thereby building up a local monitoring system.

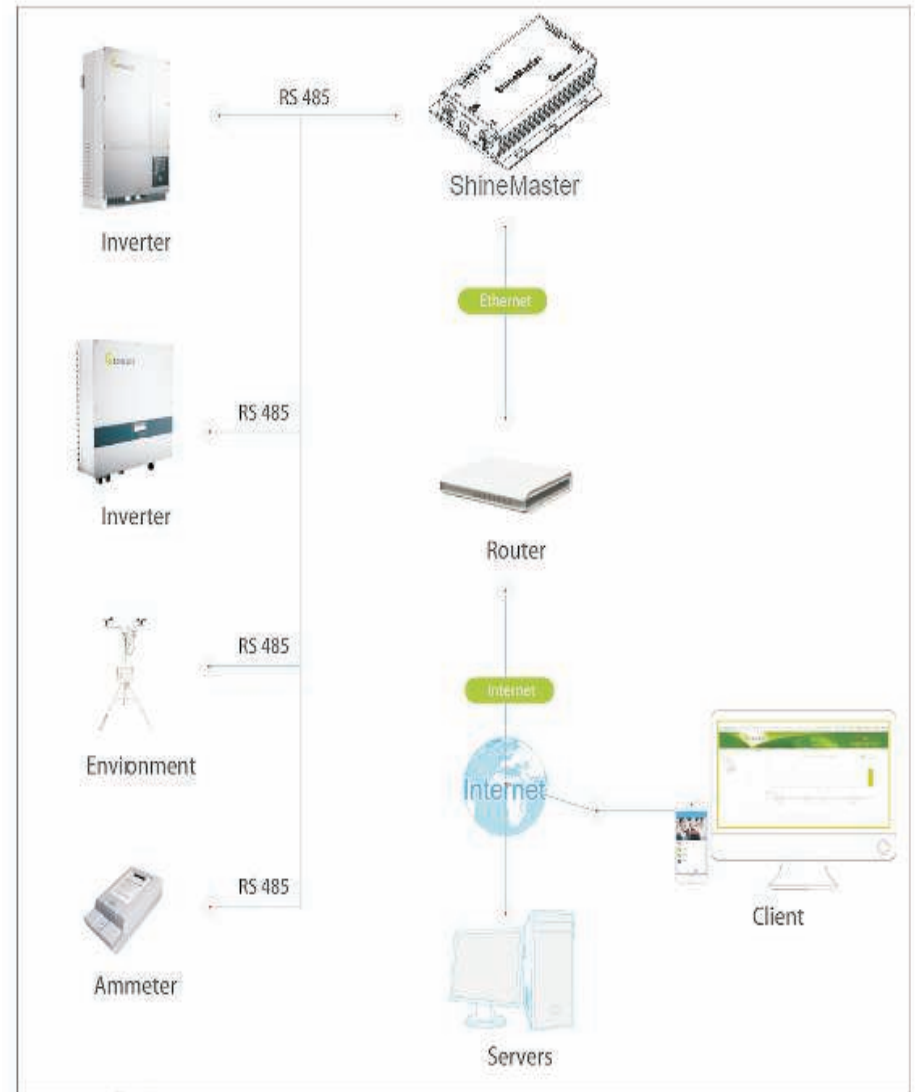

Fig 2-5

3 Installation and Connection

3.1 ShineMaster installation

The installation environment of ShineMaster and communication with other devices:

- (1) Indoor installation, temperature - 40 ~ 60°C , avoid moisture and direct sunlight.
- (2) Cable RS485 in maximum 500m.

3.2 ShineMaster installation

3.2.1 Installation Procedure

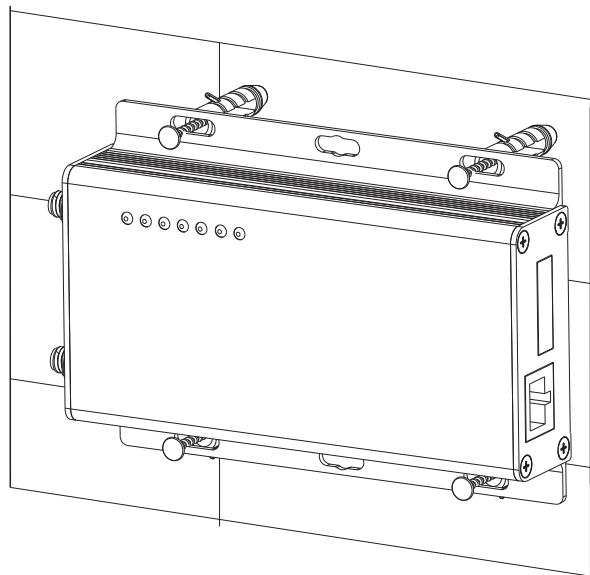

The installation steps are as follows:

- (1) Install ShineMaster on a vertical plane or horizontal plane.
- (2) Connect cables between RS485 interface and RS485 interface on ShineMaster (please refer to 3.3.1 below for details)
- (3) Connect the network cable (insert the network line into the LAN interface on ShineMaster).
- (4) Connect the Power supply (connect the power cord to the Power interface on ShineMaster).

3.3 Connect to the photovoltaic device

ShineMaster can communicate with the inverter, weather station, smart meter, combiner box and other photovoltaic devices to achieve the purpose of data collection.

3.3.1 RS485 cable connection

1. ShineMaster (master) communicates with slave devices via RS485 wired connection. 485A+ on the RS485 port of the slave device corresponds to A1+ or A2+ on the ShineMaster 485 port, 485B- and ShineMaster 485 on the RS485 port of the slave device. Corresponding to B1- or B2-. The following is a schematic diagram of the connection between the ShineMaster and the inverter:
Note: the RS485 shielded wire must be ground (PE) for long distance communication, so as not to affect the communication stability.

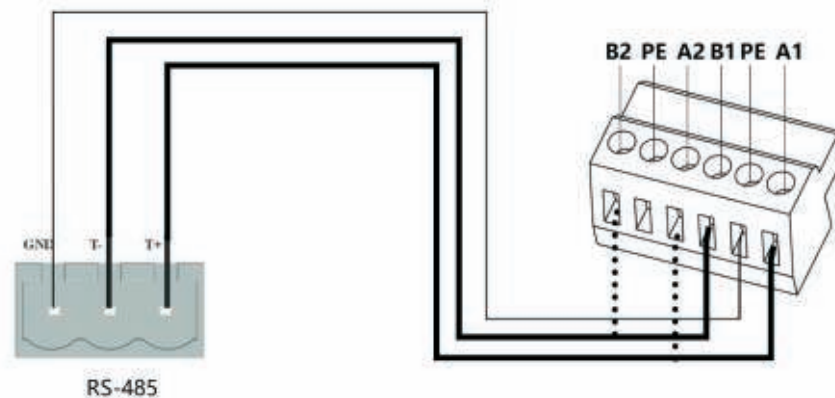

2. Note that the inverter also has an interface like the one below:

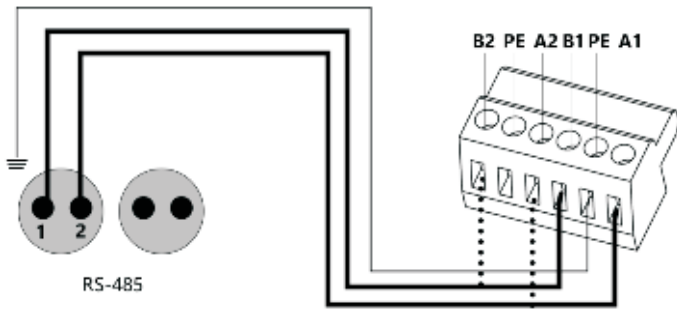

3. The inverters are connected to the ShineMaster via RS485 serial connection. Using the RS485 wired communication connection, the ShineMaster can monitor up to 32 inverters stably.

4. The ways of ShineMaster connection to Smart meter, combiner box and environmental monitor are similar to the connection of inverters. The weather station can be connected to the inverter in series, and the communication line of the smart meter can be directly connected to the ShineMaster RS485 port.

Note: The weather station, combiner, and smart meter manufacturers must be designated by Growatt, otherwise monitoring will not be possible.

4 ShineMaster Internal Page

4.1 ShineMaster IP address query

1. Connect the PC computer and the ShineMaster LAN port to the network port of the router through the network cable so that they are in the same LAN.

2. Go to the router's management page and check the "Internet host list" to query the IP address of the ShineMaster IP address with the serial number of the ShineMaster as the device name. This IP address is the IP address assigned by the router to the ShineMaster. If you do not know how to do this, contact your network administrator to perform the operation.

Note: The router needs to enable automatic IP assignment, that is, open the DHCP function

3. Enter the ShineMaster IP address in the browser to enter the ShineMaster internal page

4.2 ShineMaster built-in page access

Before accessing, check whether the communication cable between the devices is securely connected. then you can enter the ShineMaster IP address in the IE browser to access the built-in page of ShineMaster. As long as the ShineMaster is on the same domain as the computer you are accessing, you can access the Shine WebBox built-in server.

1. If the user successfully access the ShineMaster internal page, you can directly enter the built-in page login interface, as shown in Figure 4-1

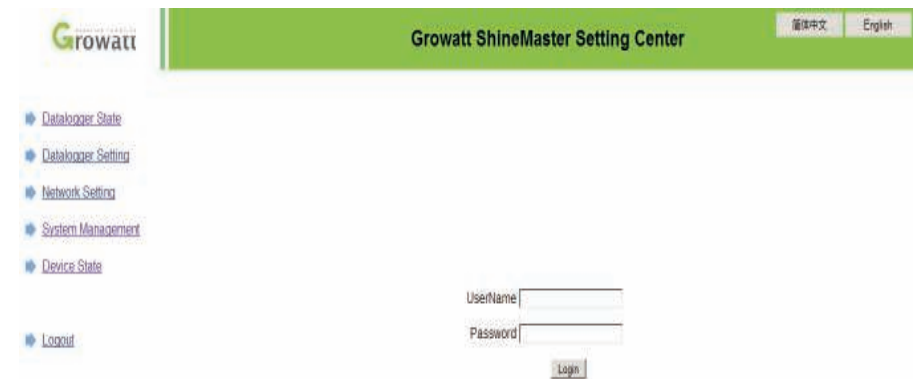

Fig 4-1

2. Enter the user name and password, the default login user name: admin password: admin, fill in and click on login to enter the Growatt ShineMaster system page.

4.3 ShineMaster Status View

Click the ShineMaster datalogger Status to view information such as the “System Status Information”, “Serial Number”, “Server Address”, “Number of Connected Devices”, etc. of the ShineMaster



4.4 ShineMaster Datalogger managing

Devices should be added in 'ShineMaster datalogger setting' interface in internal page prior to monitoring

4.4.1 Add device

(1) Before ShineMaster monitors photovoltaic equipment, it is necessary to enter the “ShineMaster Data Collector Settings” page of the built-in page to add devices.



(2) In the second drop-down list, select the type of monitored device

Device types parameter information:
 INVERTER: GROWATT Inverter;
 SDM120: single phase meter;
 SDM630: three phase meter;
 BatterBox: battery Box;
 Surveymeter: Survey Meter.

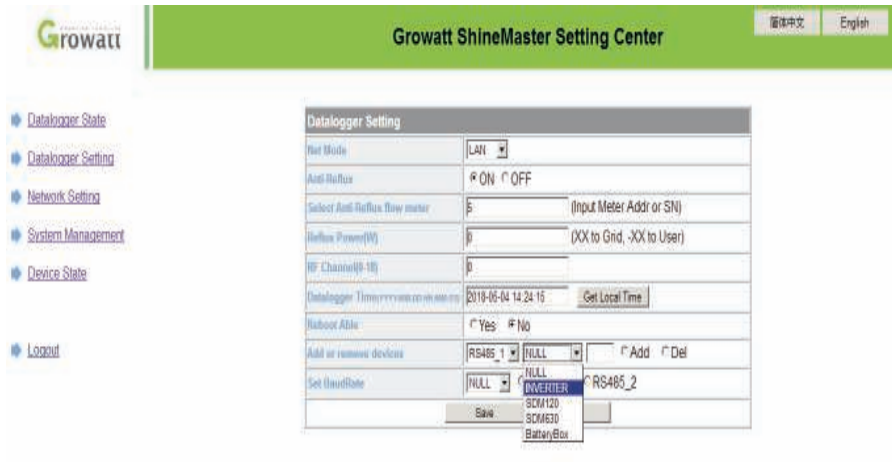

(3) In the third drop-down list, fill in the communication address of monitored device



(4) Select "Add" and click Save.

(5) After successfully saving, enter the "Device Status" page to confirm whether the device is added successfully.



4.4.2 Remove device

(1) Select the monitoring method for monitoring PV devices in the first drop-down list of "Add or Remove Devices".

(2) In the second drop-down list, select the type of PV plant being monitored.

(3) Fill in the PV device communication address in the third drop-down list.

(4) Select "Del" and click Save to finish removing of the device.

(5) After successfully saving, enter the "Device Status" page to confirm whether the device is successfully deleted.

As shown in the picture:



Add and delete device:

1. When you need delete a device, all the options should be the same with the momemet you add this device like: 485 channel, device type, address, if you are not sure about this you can check the device status first.
2. When one address is occupied, you cannot just paste the new device, you have to delete the old device and use this address.

4.5 Baud Rate Setting

The Default two channels' Baud Rate are both 9600, you can adjust the Baud Rate for different scenarios.

- (1) Choose the Baud rate at the "Baud rate setting " Bar.
 - (2) Choose the corresponding chanel RS485_1 or RS485_2.
- Set the Baud rate to 9600 as RS485_1



4.6 Server Address and Shine Master IP setting

4.6.1 Data logger IP Setting

(1) ShineMaster's Default setting of the DHCP function is "ON" it will automatically get IP address. ShineMaster



(2) If you need a fixed IP address you need following steps

- (2.1) Turn off the "Dynamic IP" to shut down the DHCP function
- (2.2) Put in the fixed IP, network management, net mask and DNS then click "Save"



4.6.2 Server Address Setting

The Server Address will choose two methods, one is IP and one is domain name, you can only use one at a time.

- (1) When you are using Server IP to connect the server please turn off the "domain name analysis function", set the server as 120.77.127.135.



(2) when you are using the domain name to connect server you can choose on at "Domain Name Analysis Function" set the server as server-cn.growatt.com



Server port name and data upgrade interval are fixed cannot be changed

Caution:

1) If you add a device, after saving there is no refreshment, please disconnect the data logger and restart it.

5 Server: Shineserver's operation

If needed to the datalogger and all monitoring devices for data display, monitoring, and set up parameters by the server, you need to first add datalogger to the server, when Shinemaster added to the server, if the subsequent need to modify some parameters of The datalogger or enable, disable a function can be done through the server.

5.1 Registration and login

(1) Enter the address of the server on the computer browser to enter the ShineServer login page. If you are logging in for the first time, register the user name first. Enter the domain name access page, as shown in Figure 5-1.

The Chinese user server domain name is: <http://server-cn.growatt.com>

The overseas user server domain name is: <http://server.growatt.com>

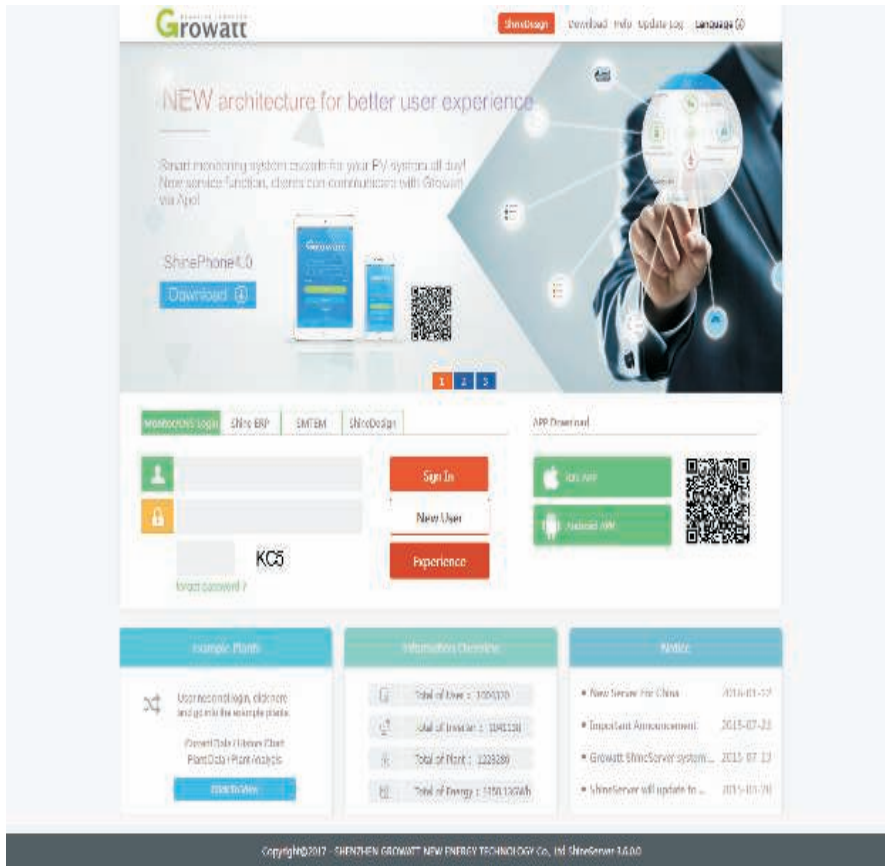

Figure 5-1 Shine Server login page

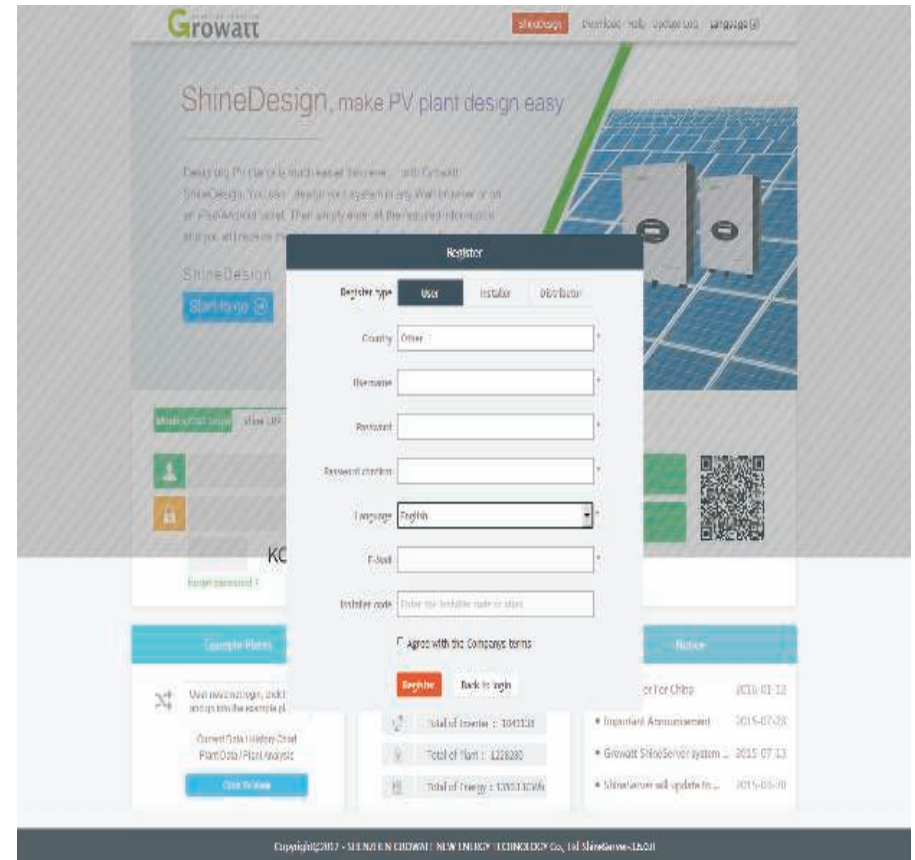

Fig 5-2

5.2 View monitoring data

(2) Register the user name and input the user information according to the pop-up. After the information is completed, click "Register".
 Note: "ShineMaster serial number" and "datalogger check code" seen on the package box.

(1) After the registration is completed, it will automatically jump to the ShineServer main interface. Click "plant" → "plant data", and the displayed information is the total power chart of the plant on the day. The drop-down list "Select collector" can be used to view the daily power chart of a single inverter in the power station.

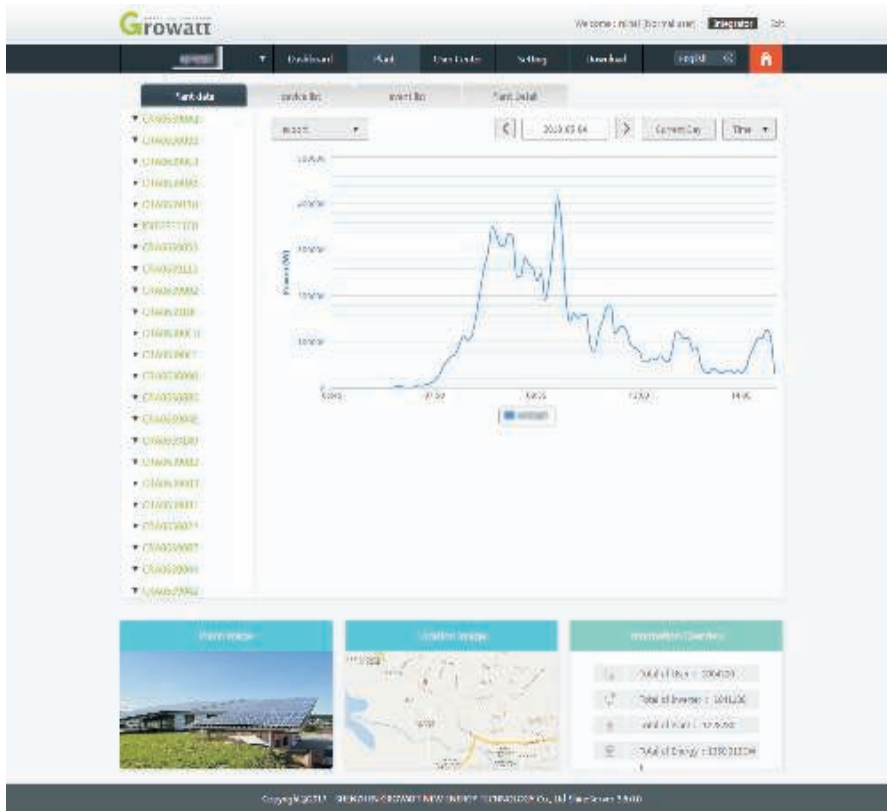

Fig 5-3

(2) Click "plant" → "Device list" to see real-time data monitored by datalogger, "Inverter", "Weather station", "Smart Meter", and "Combined Box" "MAX".

5.3 Add or Delete Monitoring devices, change the ShineMaster Baud rate

5.3.1 Add or Delete Monitoring device

(1) In the Server page click the "Device Management" and then click "Data Logger". In this page click set the device updating icon.



(2) Add one device, add one Growatt inverter set the 485 communication address is 1.

(3) Delete one device, just like following figure.

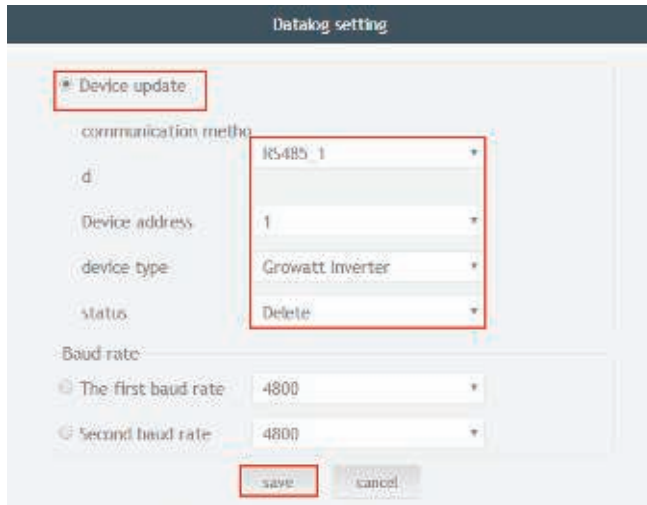

(4) Above adding or deleting devices if success following figure will pop out.

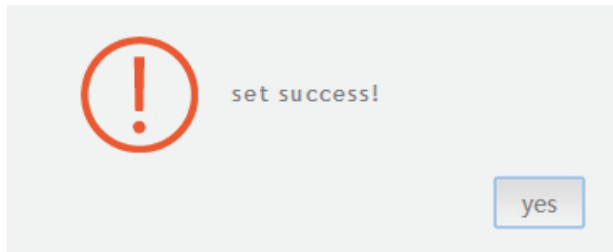

5.3.2 Change ShineMaster Baud rate.

(1) In the Server page click "Device Management" then click "Data Logger", click the Baud rate setting icon.



(2) Set chosen channel's baud rate.

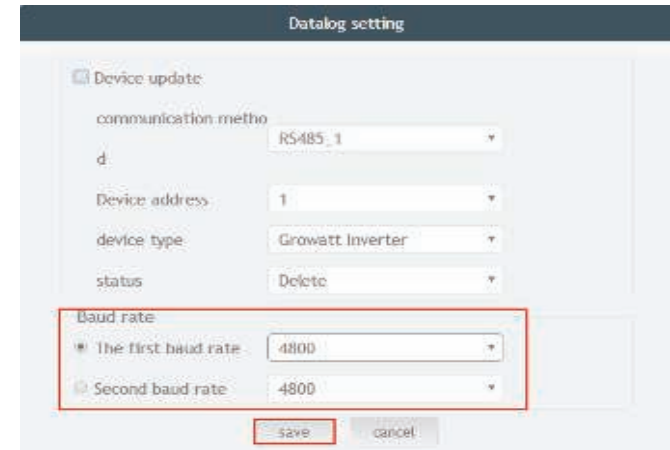

(3) If success following figure will pop out.

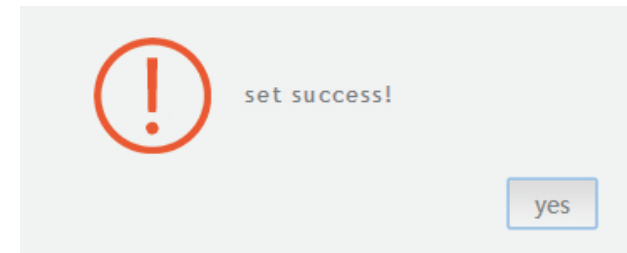

Note: The second channel of Baud rate setting would be the same as the first channel.

6 Device Maintenance

6.1 Reset ShineMaster

If you press the “reset” button for five seconds, it will erase all the registered device information. All the information for the server communication part will be kept.

6.2 Common faults and troubleshooting

Fault	Cause	Suggestion
Cannot enter the ShineMaster internal page	ShineMaster can not obtain the IP	1.Enable Router DHCP Function 2.PC and the ShineMaster must be in the same domain.
ShineMaster built-in page "System Status Information" shows not connected	Unable to connect to server	1.Check whether the router network is connected to the Internet. 2.Check if the "server address" is correct The Chinese user server domain name is: http://server-cn.growatt.com The overseas user server domain name is: http://server.growatt.com
ShineMaster is online, but the monitored device is disconnected after logging in to the account	1.Monitor connection failed 2.No access to the built-in page to add equipment 3.Inconsistent Photovoltaic equipment address and added equipment address 4.Illegal PV device serial number	1.Check the communication line is in contact with the stability 2.Enter the built-in page "datalogger settings" to add photovoltaic devices 3.On the "Device Status" page of the built-in page, check whether the device's communication address is consistent with the added device. 4.Check whether the serial number of the monitored PV equipment is 10 digits. It can only contain English letters and numbers, and there are no illegal characters.
Long time no refresh interface after operation	Configuration page does not respond	Refresh the page or login in again.

6.3 Maintenance

1. Avoid frequent switching of power supply, gently handle, to prevent damage;
2. ShineMaster is a product for indoor use. Do not place ShineMaster in a humid environment or in direct sunlight.

7 Technical specifications

7.1 ShineMaster specification

General specification

Length * width * height	130mm*84mm*25mm
Net Weight	180±g
Protection grade	IP30

Operating environment

Ambient temperature	-40°C~ +60°C
Installation	Indoor

Communication

Wireline communication	RS485 maximum stability monitoring 32 inverters
Wireless communication	Not supported temporarily
RS485 communication distance	500 meters maximum (twisted shielded cable)

8 Contact us

Growatt New Energy provides customers with a full range of technical support. Users can contact the nearest Growatt new energy office or customer service point, or they can contact the company's customer service center directly.

Name: SHENZHEN GROWATT NEW ENERGY TECHNOLOGY CO.,LTD

Address: No.28 Guangming Road, Shiyan Street, Bao'an District, Shenzhen, P.R.China

Customer Service Hotline: +86 755 27471942

E-mail:service@ginverter.com

Company website: www.ginverter.com